

ARTM-Pn 无线测温采集装置

ARTM-Pn wireless temperature measuring equipment

安装使用说明书 V1.9

Installation & Operation Manual V1.9

安科瑞电气股份有限公司

Acrel Co., LTD.

申明

DECLARATION

版权所有，未经本公司之书面许可，此手册中任何段落，章节内容均不得被摘抄、拷贝或以任何形式复制、传播，否则一切后果由违者自负。

本公司保留一切法律权利。

All rights reserved. No part of this publication may be reproduced, stored in a retrieval system, or transmitted in any form by any means, electronic, mechanical photocopying, recording, or otherwise without prior permission of our company. The violator will bear the dependent legal responsibility.

We reserve all the rights.

本公司保留对本手册所描述之产品规格进行修改的权利，恕不另行通知。

订货前，请垂询当地代理商以获悉本产品的最新规格。

We reserve all the rights to revise product specification without notice. Please consult local agent to get the latest information of our products specification.

目 录

1 安装使用指南.....	1
1 Installation Guide	1
1.1 产品概述.....	1
1.1 Product Introduction	1
1.2 型号说明.....	2
1.2 Type Introduction	2
1.3 技术指标.....	2
1.3 Technical Features	2
1.4 产品安装.....	5
1.4 Product Installation	5
1.4.1 安装方法.....	5
1.4.1 Installation Method.....	5
1.4.2 开孔尺寸.....	5
1.4.2 Hole Size	5
1.4.3 无线温度收发器的安装.....	6
1.4.3 Wireless Temperature Coordinator Installation	6
1.4.4 无线温度传感器的安装.....	7
1.4.4 Wireless Temperature Sensor Installation.....	7
1.5 接线方法.....	14
1.5 Wiring Method	14
1.5.1 接线端子.....	14
1.5.1 Wiring Connector	14
1.5.2 开入接线图.....	15
1.5.2 DI Wiring Diagram	15
1.5.3 开出接线图.....	15
1.5.3 DO Wiring Diagram	15
1.5.4 电参量接线图.....	15
1.5.4 ELEC Wiring Diagram	15
1.6 配置方案.....	16
1.6 Solution	16
1.6.1 有源无线温度传感器方案（电池供电）.....	16
1.6.1 Active Wireless Temperature Sensor Solution (Battery-powered).....	16
1.6.2 无源无线温度传感器方案（CT取电）.....	17
1.6.2 Passive Wireless Temperature Sensor Solution (CT-powered).....	17

1.7 系统方案.....	18
1.7 System Solution.....	18
2 产品操作指南.....	18
2 Product Operation Guide	18
2.1 显示介绍.....	19
2.1 Display Instruction.....	19
2.2 操作介绍.....	19
2.2 Operation Instruction.....	19
2.2.1 装置上电.....	19
2.2.1 Device Power On	19
2.2.2 开关量输入.....	19
2.2.2 Digital Input.....	19
2.2.3 继电器输出.....	20
2.2.3 Relay Output	20
2.2.4 无线测温.....	20
2.2.4 Wireless Temperature Measuring	20
2.2.5 电力参数测量.....	20
2.2.5 Electric power parameter measurement	20
2.3 ARTM-Pn 操作方法.....	21
2.3 ARTM-Pn Operation Method	21
2.4 ARTM-Pn 操作流程.....	24
2.4 ARTM-Pn Operation Process	24
3 通讯指南.....	25
3 Communications	25
3.1 通讯格式详解.....	25
3.1 Communication Examples.....	25
3.1.1 读取状态（功能码 02H）	26
3.1.1 Read State (Function code 02H).....	26
3.1.2 读取数据（功能码 03H/04H）	26
3.1.2 Read Data (Function code 03H/04H)	26
3.1.3 预置单个寄存器（功能码 06H）	27
3.1.3 Preset Single Register (Function code 06H)	27
3.1.4 预置多个寄存器（功能码 10H）	27
3.1.4 Preset Multi Registers (Function code 10H).....	27
3.2 参量地址表.....	28

3.2 Parameter Address Table	28
4 常见故障的诊断分析与排除方法.....	33
4 The Analysis and Solvent of Some Faults	33
4.1 辅助电源故障.....	33
4.1 Power Source Fault.....	33
4.2 告警继电器动作故障.....	33
4.2 Relay Output Fault.....	33
4.3 通信故障.....	33
4.3 Communication Fault	33
4.4 节点温度值显示故障.....	34
4.4 Wireless Temperature Fault	34

1 安装使用指南

1 Installation Guide

1.1 产品概述

1.1 Product Introduction

ARTM-Pn 无线测温采集装置根据《NB/T 42086-2016 无线测温装置技术要求》开发,可用于 3~35kV 户内开关柜,包括中置柜、手车柜、固定柜、环网柜等多种开关柜,也可用于 0.4kV 低压柜,包括固定柜,抽屉柜等。无线温度传感器可安装于柜内任何发热点上,利用无线数据传输技术,可实时把监测数据发送出去,通过 ARTM-Pn 无线测温采集装置就地显示温度,也可以通过装置的 RS485 接口互联组网实现远程智能监控。

ARTM-Pn wireless temperature measuring equipment has been developed in compliance with *Specification for Wireless Temperature Measuring equipment, NB/T 42086-2016*. It is suitable for 3-35kV indoor switchgears, including built-in switchgears, handcart switchgears, fixed switchgears and loop-net switchgears. It is also suitable for 0.4kV low-voltage switchgears such as fixed switchgears and drawer switchgears. The wireless temperature sensors can be installed at any heating point in switchgears, the device utilizes the wireless data transmission technology for real-time transmission of monitored temperature data and displays such data on ARTM-Pn locally. In addition, it can be networked via the RS485 port for remote intelligent monitoring.

1.2 型号说明

1.2 Type Introduction

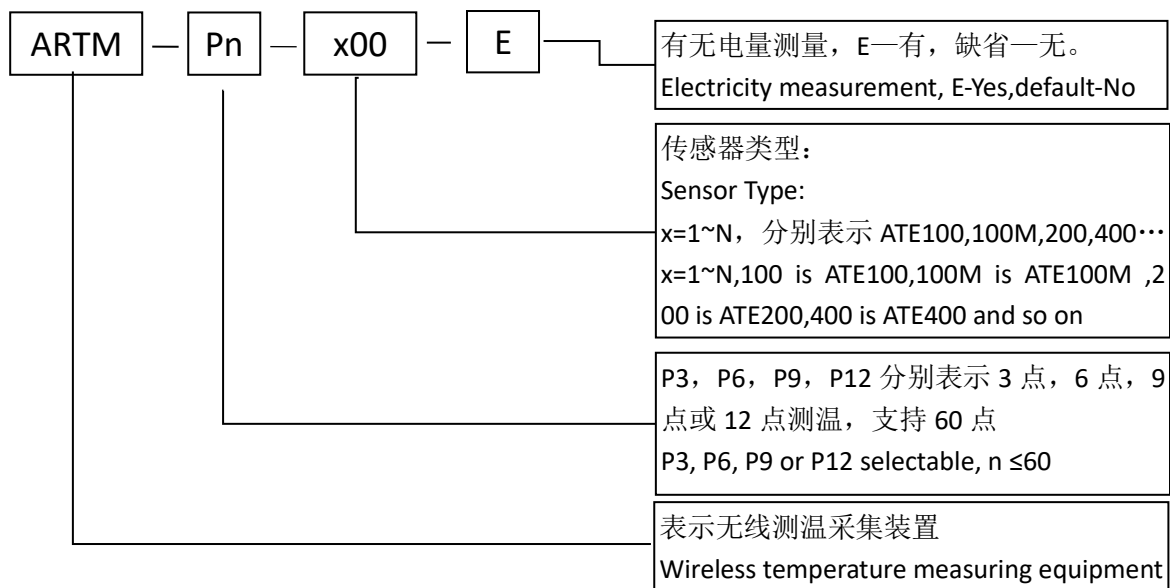

1.3 技术指标

1.3 Technical Features

项目 Items		指标 Features
额定输入 Rated input	接线方式 Wiring mode	3P3L 或 3P4L 3P3L or 3P4L
	电压 Voltage	100V
	电流 Current	5A
	频率 frequency	50Hz
准确度 Accuracy rating	电流、电压 Current、Voltage	0.5 级 0.5 class
	有功功率 Active power	0.5 级 0.5 class

	无功功率 Reactive power	0.5 级 0.5 class
	电能 Energy	0.5 级 0.5 class
辅助电源 Power Source		AC85~265V, DC100~300V
功耗 Power Consumption		8W
通讯 Communication	协议 Protocol	Modbus-RTU
	波特率 (bps) Baud rate (bps)	2400、4800、9600、19200
环境要求 Environment	工作温度 Temperature	-10℃~55℃
	相对湿度 Humidity	≤95%
	大气压力 Atmospheric pressure	86kPa~106kPa
平均无故障工作时间 MTBF		≥50000 h
有源无线温度传感器 Active wireless temperature sensor	无线频率 Wireless frequency	470MHz
	通讯距离 Communication distance	空旷 150m 150m in open area
	采样频率 Sampling frequency	25s
	发射频率 Transmitting frequency	25s~5min
	工作电源 Power source	电池 Battery
	安装方式 Installation	磁吸式/螺栓式/表带式 Magnetic / bolted /Belt
	测温范围 Range of temperature	-50℃~+125℃
	精度 Precision	±1℃
	应用范围 Application	高低压柜内电气接头 Joints in high or low voltage switchgears
	电池寿命 Battery life	≥5 年 ≥5 years
无源无线温度传感器 Passive wireless temperature sensor	无线频率 Wireless frequency	470MHz
	通讯距离 Communication distance	空旷 150m 150m in open area

	采样频率 Sampling frequency	15s
	发射频率 Transmission frequency	15s
	工作电源 Power source	CT 感应取电, 启动电流 $\geq 5A$ CT-powered, starting current $\geq 5A$
	安装方式 Installation	合金片固定 Alloy chip fixing
	传感器探头 Sensor probe	合金底座 Alloy bottom
	测温范围 Range of temperature	$-50^{\circ}C \sim 125^{\circ}C$
	精度 Precision	$\pm 1^{\circ}C$
	应用范围 Application	高低压柜内电气接头 Joints in high or low voltage switchgears
户外无线温度传感器 Outdoor wireless temperature sensor	无线频率 Wireless frequency	470MHz
	通讯距离 Communication distance	空旷 150m 150m in open area
	采样频率 Sampling frequency	25s
	发射频率 Transmitting frequency	25s~5min
	工作电源 Power source	电池 Battery
	安装方式 Installation	螺栓式/表带式 bolted /Belt
	测温范围 Range of temperature	$-50^{\circ}C \sim +150^{\circ}C$
	精度 Precision	$\pm 0.5^{\circ}C$
	应用范围 Application	户外电气接头 Outdoor voltage switchgears
	电池寿命 Battery life	≥ 5 年 ≥ 5 years
	防护等级 Protection level	IP68

1.4 产品安装

1.4 Product Installation

ARTM-Pn 无线测温采集装置采用面板嵌入式安装, 首先柜体盘面上制作规定尺寸的正方形槽孔, 装置取下支架后嵌入槽孔, 再将支架推入卡槽锁紧即可。

ARTM-Pn wireless temperature measuring equipment is installed with the front panel embedded. First, make a square hole on the switchgear surface to the specified size. Then, separate the two brackets from device and embed the device into the square hole. Finally, push and lock the brackets.

1.4.1 安装方法

1.4.1 Installation Method

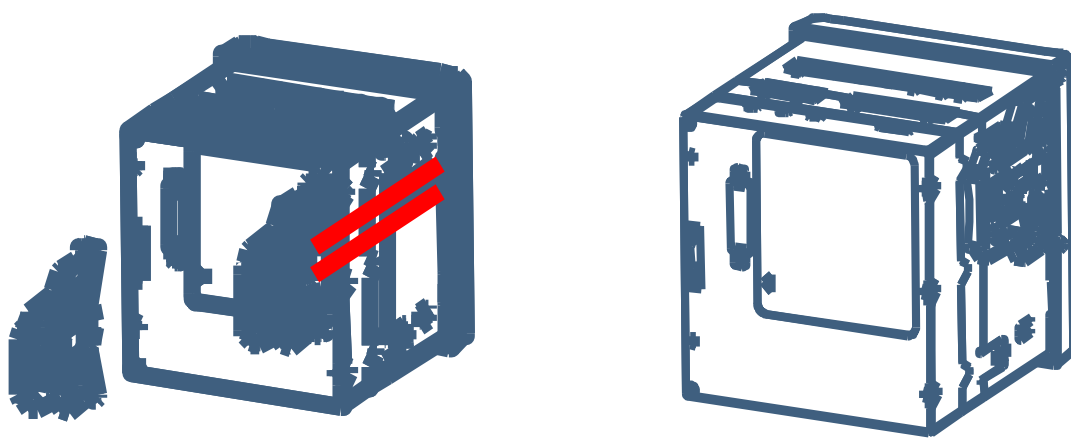

1.4.2 开孔尺寸

1.4.2 Hole Size

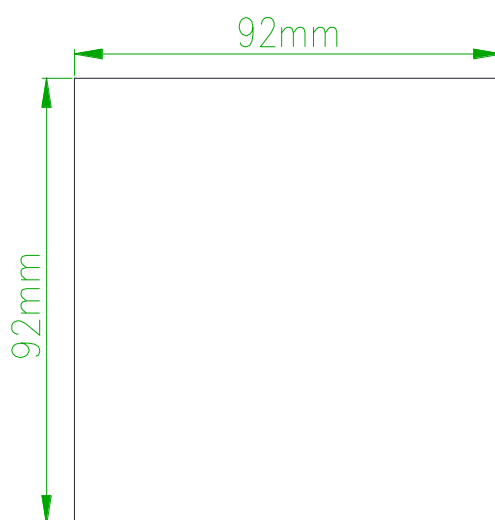

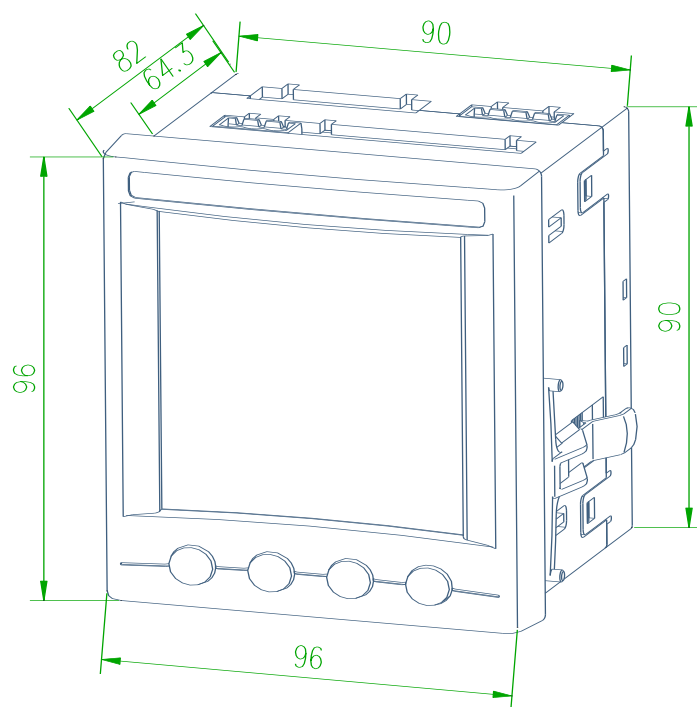

1.4.3 无线温度收发器的安装

1.4.3 Wireless Temperature Coordinator Installation

与 ARTM-Pn 产品配套使用的无线温度收发器，可以采用导轨（DIN35mm）安装方式，也可以使用螺栓固定方式。

The wireless temperature coordinator connected with ARTM-Pn which can be mounted on rail (DIN35mm) or bolted directly.

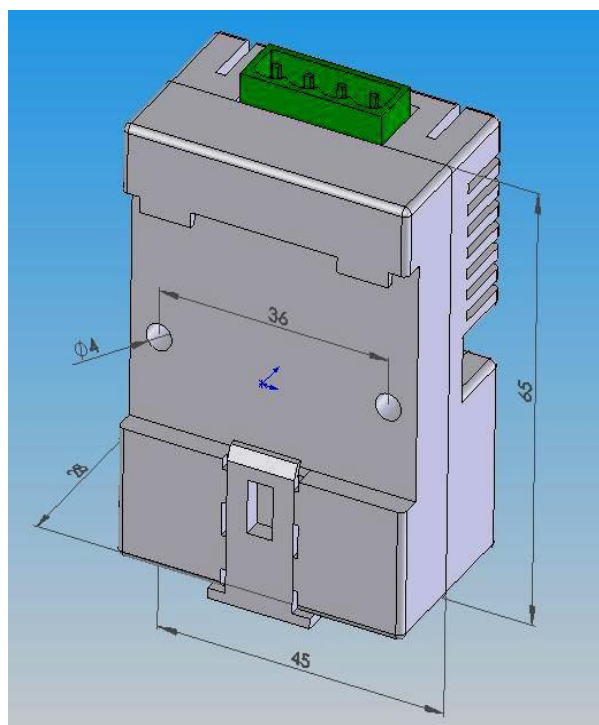
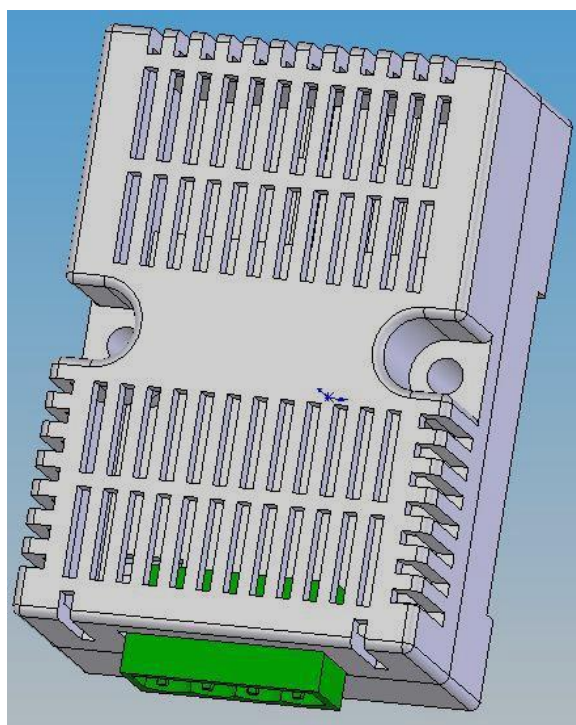

ATC 系列无线温度收发器的标签应和显示装置一致。

The label on ATC series wireless temperature coordinator should be same as it on display device.



ARTM-Pnn



ATC450

ATC series

ATC 系列无线温度收发器可以安装在仪表室、手车室或者电缆室，安装实例见下图：

The series of wireless temperature coordinator can be installed in instrument chamber, circuit breaker chamber or cable chamber; ther installation examples see images below.



1.4.4 无线温度传感器的安装

1.4.4 Wireless Temperature Sensor Installation

无线温度传感器共有多种型号，分别对应磁吸固定、螺栓固定、表带固定、合金片固定等安装方式。

There are several types of wireless temperature sensors and mounting methods correspondingly, i.e. magnetic , bolted , belt and alloy chip fixing.

1.4.4.1 外形尺寸

1.4.4.1 Shape Size

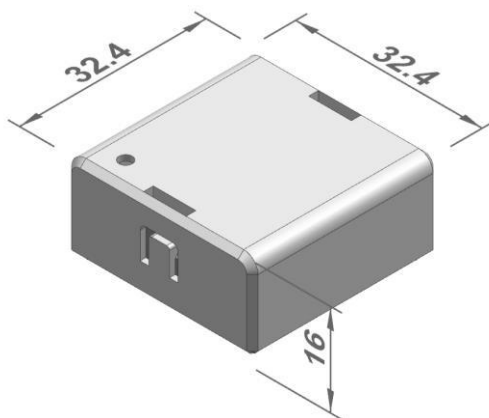

ATE100M

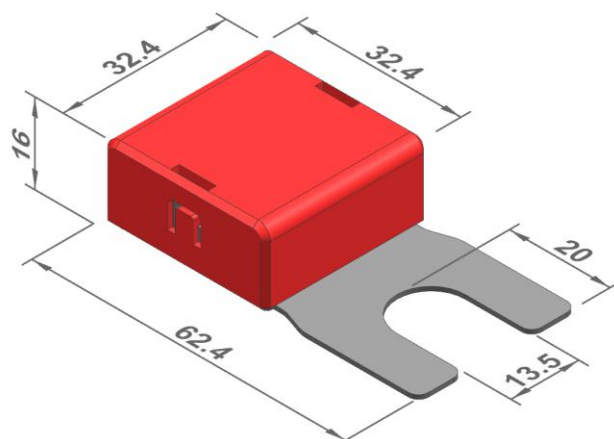

ATE100/ATE100P

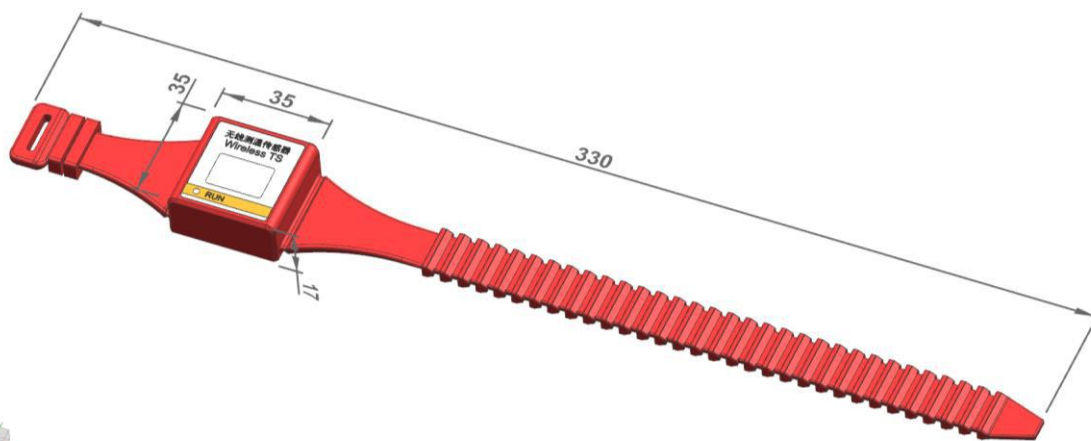

ATE200/ATE200P

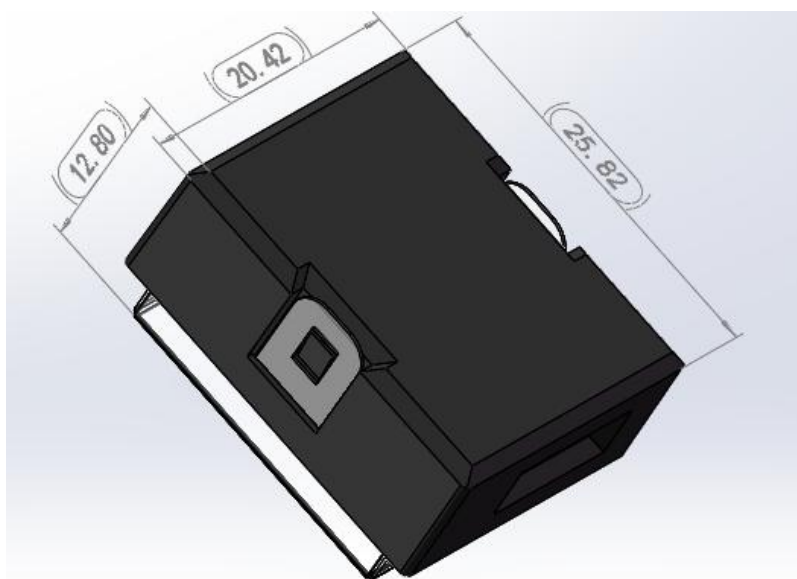

ATE400

1.4.4.2 标签说明

1.4.4.2 Label Instruction



ATE100MM



ATE100



ATE200



ATE400



ATE100P



ATE200P

如图所示，如果安装 ATE100M/ATE100/ATE200/ATE400/ATE100P/ATE200P，其组号应与显示装置标签条形码最后四位编号一致，即“组号 1”对应“*51809190240001*”，安装位置依照标签文字安装，“编码：1A”为安装第一个 A 相，“编码：1B”为安装第一个 B 相，以此类推。

See images above, if the sensor is ATE100M/ATE100/ATE200/ATE400/ATE100P/ATE200P, the number behind “组号：” should be same as number underlined in “*51809190240001*”, the sequence of installation is base on the label, “编码：1A” is first one on the phase A, “编码：1B” is first one on the phase B, and so on.

注意：出厂时包装箱内无线温度传感器与显示装置已配对，不可以与其他显示装置或无线温度传感器混用，无线温度传感器按照标签安装。

Notice: wireless temperature sensors and display device in the package have been matched before delivery. Do not use them with other display device or other wireless temperature sensors together. Please install them with label on the sensor.

1.4.4.3 ATE100M 安装方法

1.4.4.3 ATE100M Installation Method

ATE100M 磁吸式无线测温传感器适用于铁质的电气节点或设备表面。

The magnetic wireless sensor ATE100M is suitable for iron electrical nodes or equipment surfaces.

磁吸式无线温度传感器 ATE100M 结构说明:

Structure introduction of ATE100M:

- 1 — 无线温度传感器主体 The core of wireless temperature sensor ATE100M
- 2 — 测温部位 Thermo-sensitive part
- 3 — 电池开关 battery switch

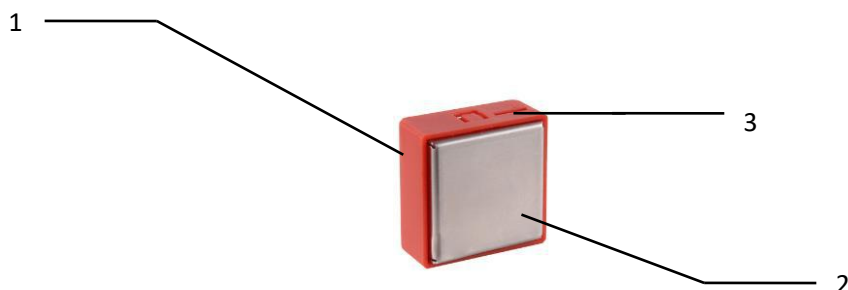

直接吸附在铁质测温点处，安装完成后打开电池开关。安装实例见下图：

Adsorbed directly at the iron temperature measuring point, open the battery switch after all of the operation. The installation examples see images below.

1.4.4.4 ATE100 安装方法

1.4.4.4 ATE100 Installation Method

ATE100 螺栓式无线测温传感器适用于电缆与母排搭接处，电缆与隔离刀闸搭接处。

The bolted type wireless sensor ATE100 is suitable for use at joints between cable and bus bar and joints between cable and disconnecter.

ATE100 螺栓式无线温度传感器结构说明:

ATE100 structure introduction:

- 1 — 无线温度传感器主体 The core of wireless temperature sensor ATE100
- 2 — 测温部位 Thermo-sensitive part
- 3 — 电池开关 battery switch

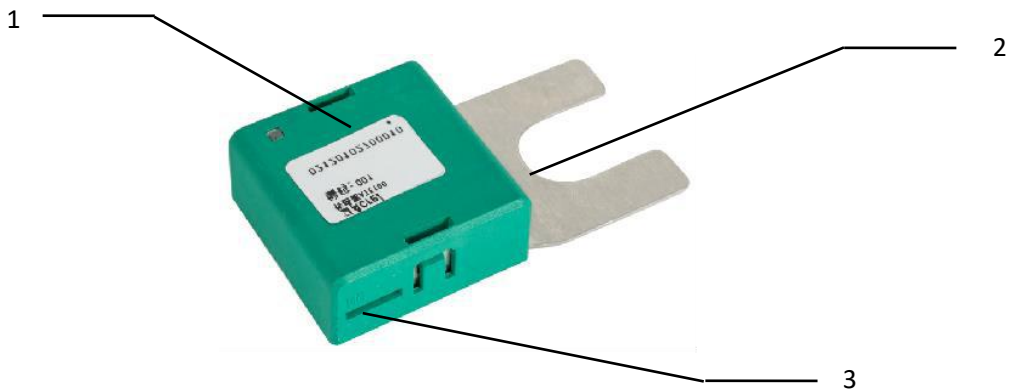

拆下安装位置搭接处的螺丝，将传感器固定在安装位置，对准合金底板的开孔，然后旋紧螺丝固定，安装完成后打开电池开关。安装实例见下图：

Remove the screw from the joints, and fixing the sensor on the position with the hole on the alloy baseplate, then tighten the screw, open the battery switch after all of the operation. The installation examples see images below.

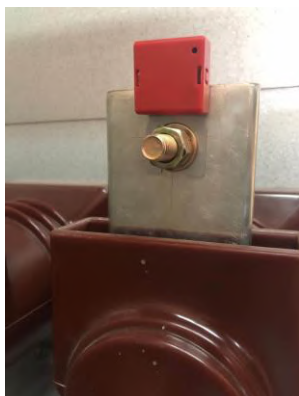

1.4.4.5 ATE200 安装方法

1.4.4.5 ATE200 Installation Method

ATE200 表带式无线测温传感器适用于断路器动触头、静触头、电缆接头、母排等处。

The strap-secured type called ATE200 is suitable for use at moving contacts and fixed contacts of breaker, cable joints and bus bar.

表带式无线温度传感器结构说明：

ATE200 structure introduction:

1 —— 无线温度传感器主体，测温探头在背面 The core of wireless temperature sensor ATE200, temperature measuring probe is on the other side

2 —— 表带及锁扣 strap and hasp

3 —— 电池开关 battery switch

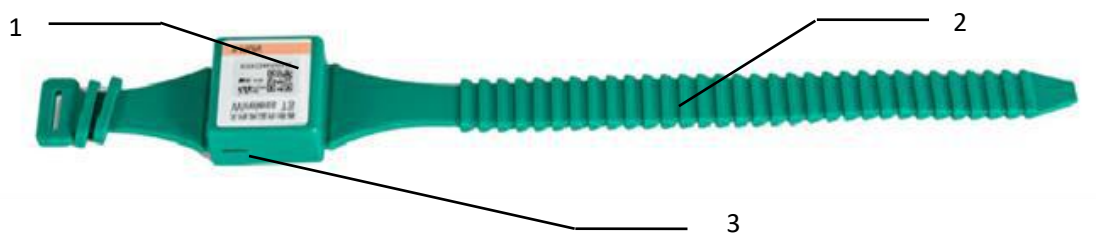

将传感器主体固定在安装位置，将表带绕过安装母排或者触头穿过表带，表带头收紧，最后将表带尾用锁扣锁紧。表带过长可以剪掉多余部分，表带过短可以联系我司增订。安装实例见下图：

Fixing the body of sensor on the position, then strapping it on the bus bar or breaker contact and frapping it through the hole on the strap, fixing the strap by hasp. Clipping the strap if it is too long when finished, if it is too short, contacting us for strap parts before installation. The installation examples see images below.

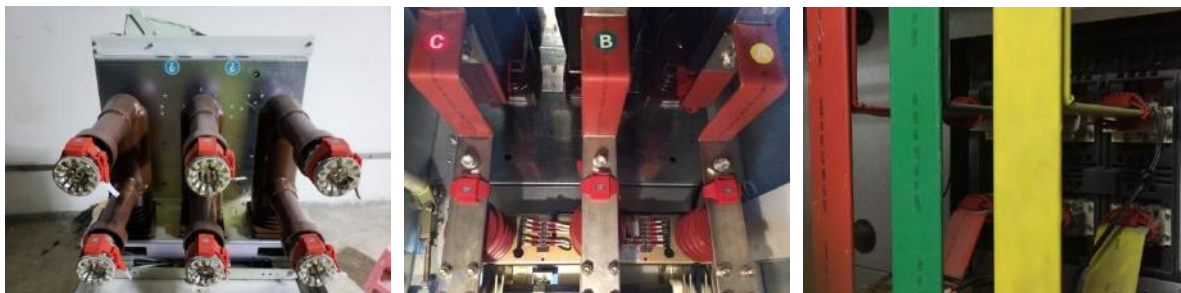

1.4.4.6 ATE400 安装方法

1.4.4.6 ATE400 Installation Method

ATE400 迷你型无线温度传感器适用于动触头，母排，电缆，母排、电缆搭接处等多种场合。

The mini type called ATE400 is suitable for using at moving contacts, bus bars, cables and joints between bus bar and cable.

迷你型无源无线温度传感器结构说明：

Mini type passive temperature sensor structure introduction:

- 1 —— 温度传感器主体 The core of wireless temperature sensor ATE400
- 2 —— 合金底座，与温度探头接触 alloy bottom, touched with temperature probe
- 3 —— 锁扣，用于固定合金片 metal hasp, for fixing alloy chip
- 4 —— 取电合金片，用于感应取电 alloy chip, for CT-powered
- 5 —— 硅胶垫片，用于支撑合金片 silicone gasket, used to support the alloy chip
- 6 —— 合金片安装孔，用于安装合金片 alloy chip hole, used to install the alloy chip

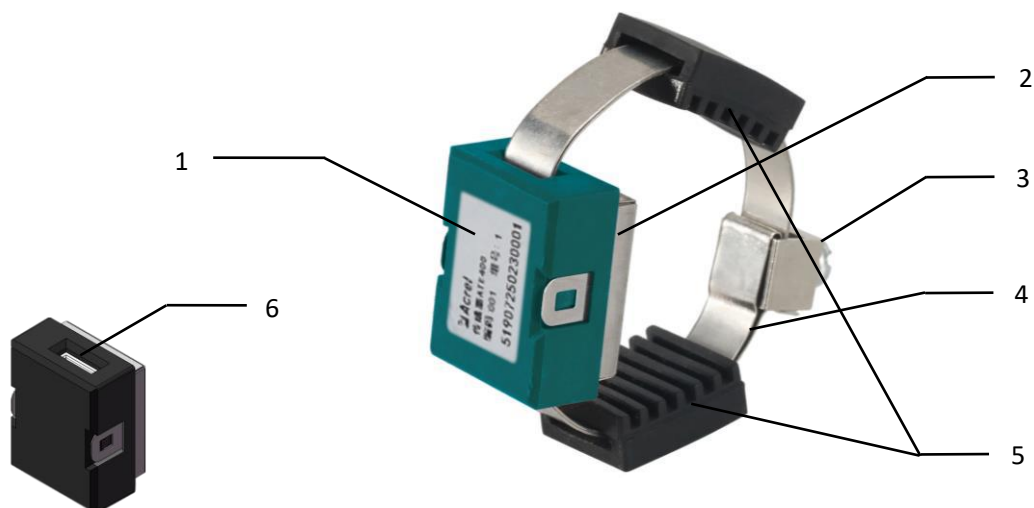

取 2 根合金片穿过锁紧件安装孔，将合金片居中对折后锁紧件固定在折弯处；将对折后的 4 层合金片分别穿过硅胶垫片-传感器主体-硅胶垫片；将整体传感器环绕安装部位一圈后拉紧合金片并旋紧螺丝；合金片多余部分留取适当长度并折叠压紧。合金片安装示意过程如下：

Firstly, take 2 pieces of alloy chips through the mounting hole of metal hasp, meanwhile fold the alloy chips and fix the metal hasp in the middle of alloy chips. Secondly, take the folded alloy chips through one silicone gasket, the core of ATE400 and another silicone gasket in turn. Thirdly, circle the whole alloy chips around the mounting position and tension the alloy chips, then tighten the screw on the metal hasp. Finally, subtract the excess alloy chips. The complete installation process is shown in Figures 1 to 4.

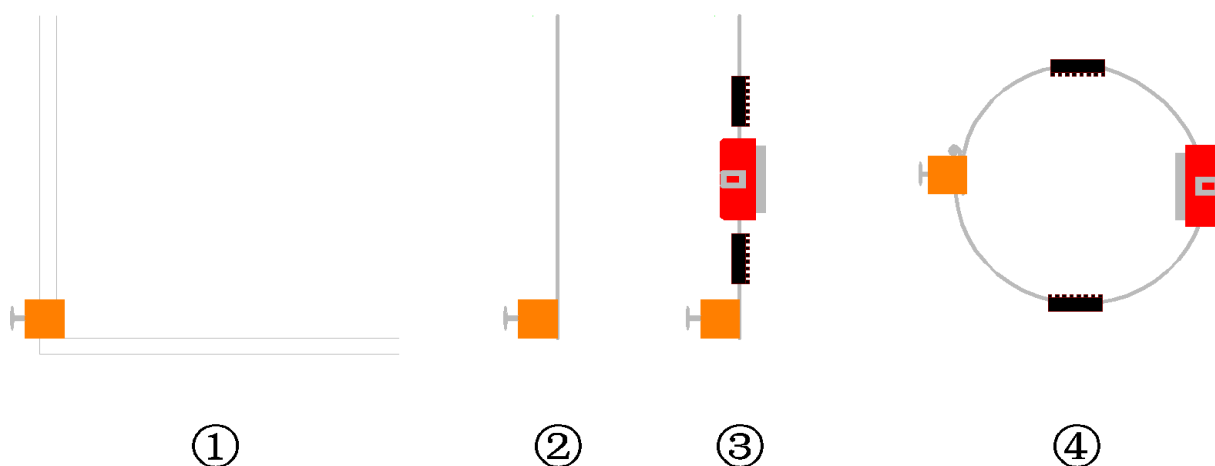

ATE400 无线温度传感器安装实例如下：

The wireless temperature sensor called ATE400 installation examples, see images below.

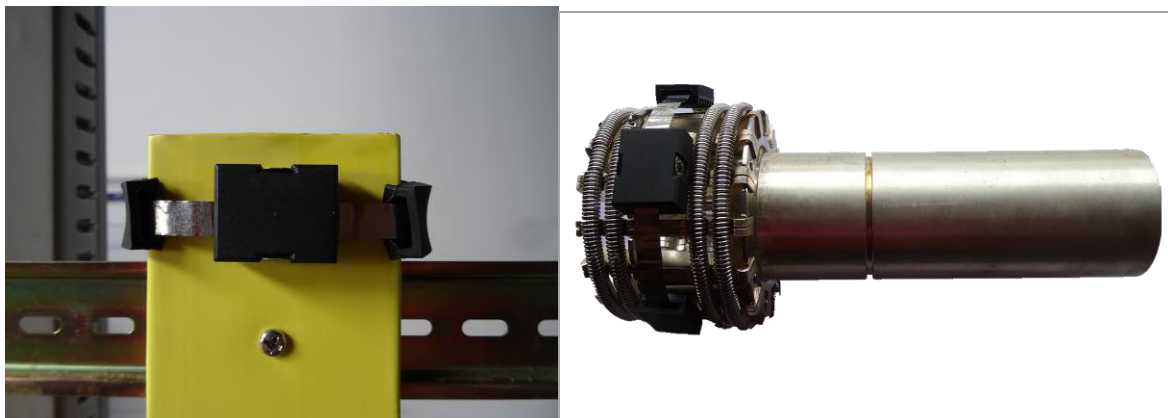

1.5 接线方法

1.5 Wiring Method

1.5.1 接线端子

1.5.1 Wiring Connector

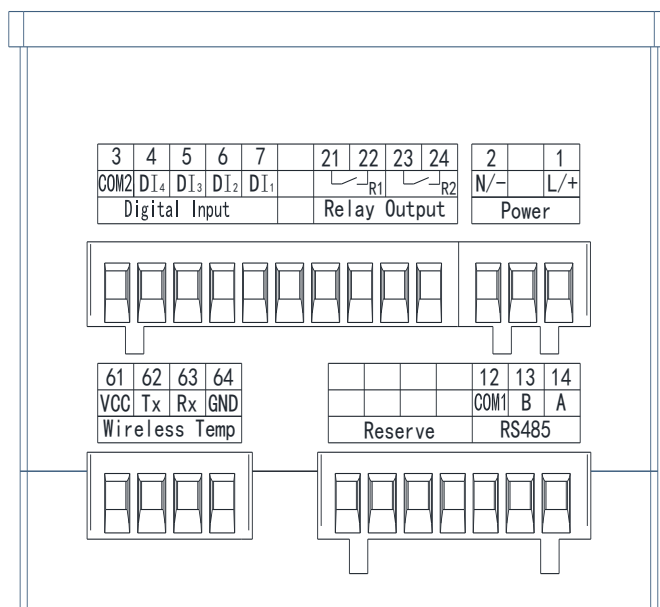

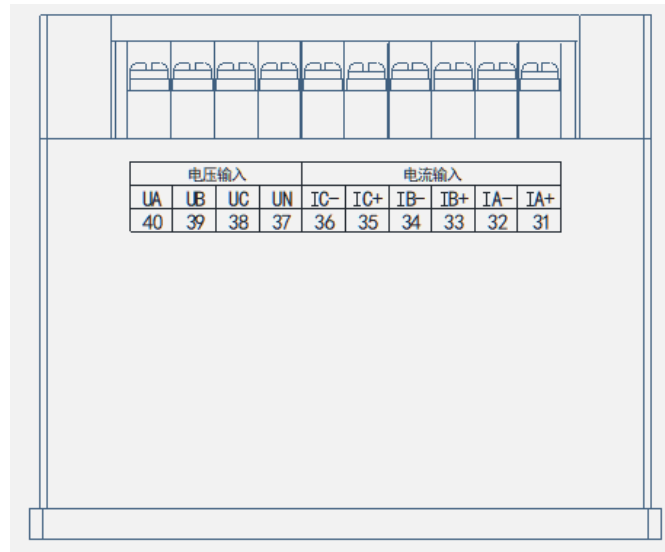

1.5.2 开入接线图

1.5.2 DI Wiring Diagram

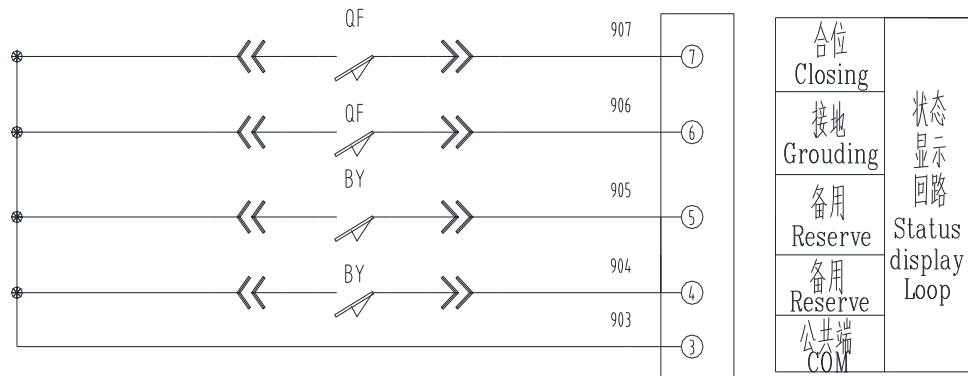

1.5.3 开出接线图

1.5.3 DO Wiring Diagram

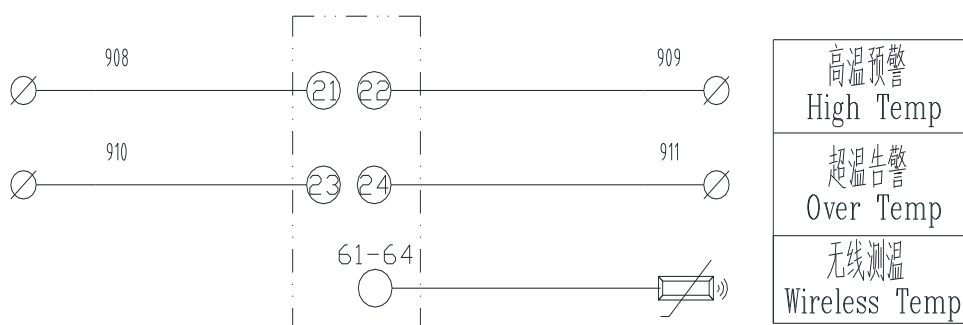

1.5.4 电参量接线图

1.5.4 ELEC Wiring Diagram

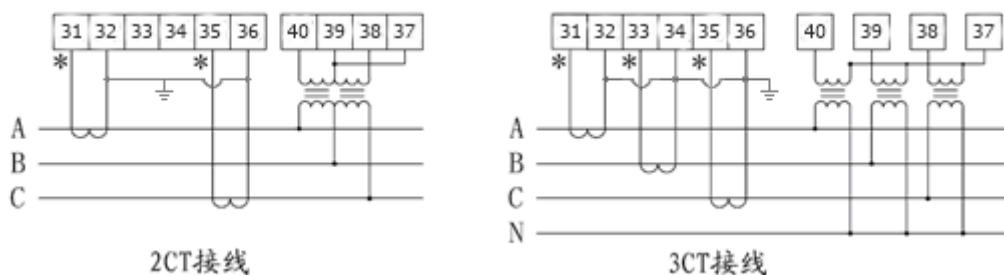

1.6 配置方案

1.6 Solution

1.6.1 有源无线温度传感器方案（电池供电）

1.6.1 Active Wireless Temperature Sensor Solution (Battery-powered)



有源无线温度传感器方案配置清单：

Active wireless temperature sensor solution list:

名称 Name	型号 Type	数量 Count
无线测温采集装置 wireless temperature measuring equipment	ARTM-Pn-100M/100/200	1
连接线 ^[1] Connected cable	27WA050-210/211	1
无线温度收发器	ATC450	1

Wireless temperature coordinator		
有源无线温度传感器 ^[2] Active wireless temperature sensor	ATE100M	n (≤60) ^[3]
	ATE100/100P	n (≤60)
	ATE200/200P	n (≤60)

注：[1]连接线有两种规格，27WA050-210/211 分别对应 4m/6m 长度，根据应用场合选择，下同
(The connected cable has two types, 27WA050-210 is 4m and 27WA050-211 is 6m. Make a selection according to the actual application, the same below)。

[2]三种无线温度传感器安装方式不同，根据具体的应用场合选择 (The three types of wireless temperature sensors are installed in different ways. Make a selection according to the actual application)。

[3] 接收 60 个无线温度传感器，根据传输距离合理配置个数。原则上，为了保证数据传输可靠性，ATE100M/100/200, ATE400 (见无源方案) 可以安装在多个柜体内

(The device can receive 60 wireless temperature sensors, make a reasonable configuration with count of sensors according to the transmission distance. In principle, ATE100M/100/200 ,ATE400 (see the next part: passive wireless temperature sensor solution) can be installed in multiple switchgears)。

1.6.2 无源无线温度传感器方案 (CT 取电)

1.6.2 Passive Wireless Temperature Sensor Solution (CT-powered)



无源无线温度传感器方案配置清单：

Passive wireless temperature sensor solution list:

名称 Name	型号 Type	数量 Count
无线测温采集装置 wireless temperature measuring equipment	ARTM-Pn-400	1
连接线 Connected cable	27WA050-210/211	1
无线温度收发器 Wireless temperature coordinator	ATC450	1
无源无线温度传感器 Passive wireless temperature sensor	ATE400	n (≤60)

1.7 系统方案

1.7 System Solution

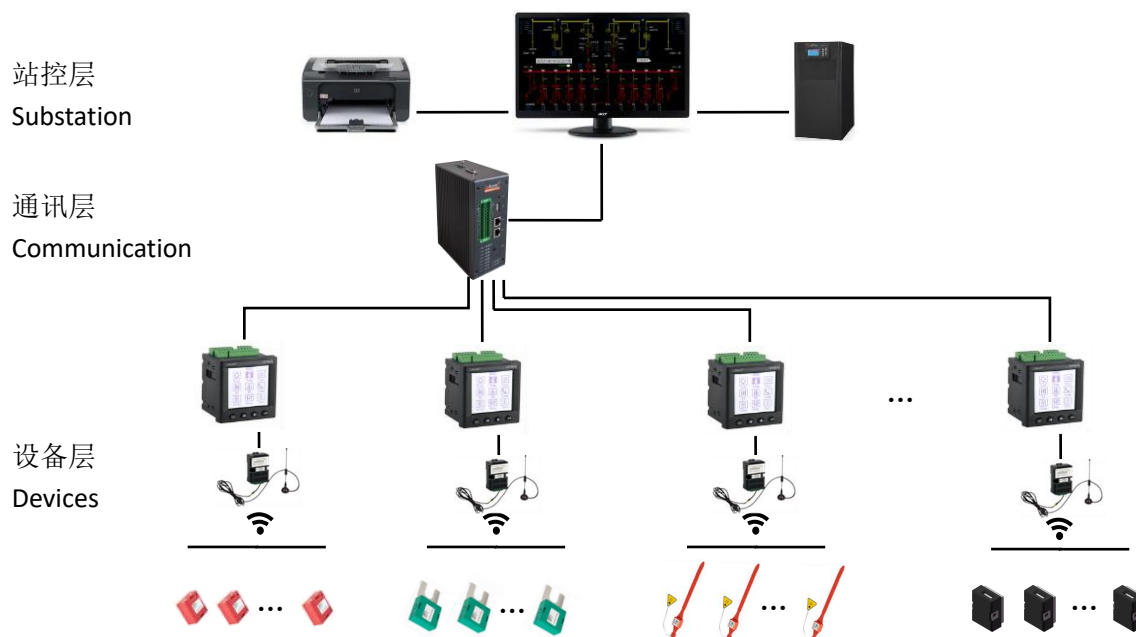

2 产品操作指南

2 Product Operation Guide

本操作说明主要针对 ARTM-Pn 无线测温采集装置。

The operation guide is suitable for ARTM-Pn wireless temperature measuring equipment.

2.1 显示介绍

2.1 Display

Instruction



2.2 操作介绍

2.2 Operation Instruction

2.2.1 装置上电

2.2.1 Device Power On

接通符合要求的工作电源，装置即进入工作状态。

After connecting with suitable power source, the device will be worked.

2.2.2 开关量输入

2.2.2 Digital Input

装置提供四路开关量输入，可以将断路器的辅助接点接入。装置上电正常工作：输入接点闭合，

开入状态界面显示该回路为 1；输入接点断开，开入状态界面显示该回路为 0。

The device provides 4 digital input, they can connect to the auxiliary contact of breaker. The device is worked after power on. If the digital input contact is closed, the DI is “1” on the DI Status interface. When the digital input contact is open, the DI is “0” on the DI Status interface.

2.2.3 继电器输出

2.2.3 Relay Output

自动定值越限继电器输出包括：无线温度传感器组 1 高温、无线温度传感器组 1 超温、无线温度传感器组 2 高温、无线温度传感器组 2 超温、无线温度传感器组 3 高温、无线温度传感器组 3 超温、无线温度传感器组 4 高温、无线温度传感器组 4 超温、无线温度传感器组 5 高温、无线温度传感器组 5 超温、无线温度传感器组 6 高温、无线温度传感器组 6 超温。高温预警为第一路继电器输出，超温告警为第二路继电器输出。

Relay output include: sensor group 1 high temperature, sensor group 1 over temperature, sensor group 2 high temperature, sensor group 2 over temperature, sensor group 3 high temperature, sensor group 3 over temperature, sensor group 4 high temperature, sensor group 4 over temperature, sensor group 5 high temperature, sensor group 5 over temperature, sensor group 6 high temperature, sensor group 6 over temperature. The high temperature alarm is first relay output, the over temperature alarm is second relay output.

注意：需将相应的控制字选择为“投入”才有效！

Notice: it is valid only when the “Node Enable” of sensor group is “ON”!

2.2.4 无线测温

2.2.4 Wireless Temperature Measuring

装置通过无线温度收发器和各无线温度传感器直接进行温度值的传输，并采用液晶显示各无线温度传感器所测温度。通过菜单可设置无线温度传感器组的高温预警值、超温告警值，当测得温度值超出设定值时，装置继电器输出触点闭合。

The device transmits the temperature values directly via the wireless temperature coordinator and wireless temperature sensors and shows temperature values measured on the LCD screen by wireless temperature sensors. Set the high temperature values and over temperature values of wireless temperature sensor groups. When measured temperature values exceed the setting values, the relay output contact will be closed.

2.2.5 电力参数测量

2.2.5 Electric power parameter measurement

装置可以测量主回路的电流、电压、有功功率、功率因数、电能等电力参数，可在装置“电量”菜单中查看，通过左/右键切换显示内容，无功功率、视在功率等可以通过通讯口读出。

Device can measure the current, voltage, active power, power factor, electric energy and other electric parameters of main circuit and check in the “electric quantity” menu of device. By left/right key

switch display content, the active power, apparent power can be read out through communication port.

电参数的显示均为一次侧值，用户需选择正确的信号接入方式及 PT 变比，以便正确显示测量值。

The display of electric parameter is all primary side value and the user shall select correct signal access way and PT no-load voltage ratio to correctly display the measured value.

2.3 ARTM-Pn 操作方法

2.3 ARTM-Pn Operation Method

(1) 上电后，装置进入节温界面，如果未绑定传感器或未接收发射器，界面显示无测温节点或节点故障；如果绑定了传感器，装置会依次显示传感器温度，通过左右键可切换温度显示界面。

(1) After the device power on, it will enter into the “temperature” interface, if it is matched without wireless temperature sensor or wireless temperature coordinator, it will show “No Nodes or Nodes Fault” on the screen. If sensors are registered, it will show the temperature values of sensors one after another, press left or right button to change the temperature interface.

(2) 节温显示界面下，按“SET”键，装置返回主菜单页面，该页面下，每一个子菜单项都由图标和相应的文字组成，左右键选择（被选中的菜单为反显状态）所需菜单项，然后按“Enter”键进入相应的子菜单。

(2) In temperature submenu, press “SET” button, it will be back to main menu interface, in main menu, each submenu consist of icon and title, press the left or right button to select submenu (selected submenu is highlighted), then press “Enter” into submenu.

(3) 主菜单页面下，选择“设置”菜单并确认，即进入系统设置界面，默认密码“0008”。

(3) In main menu, select “Conf” submenu and confirm, then enter the “Settings” interface, the default password is “0008”.

“显示设置”子菜单下可设置液晶背光时间，默认 0 秒；节温界面循环时间，默认 0 秒；

“Display” submenu, we can set the backlight time, the default is 0s; cycling time, the default is 0s

“时间设置”子菜单下可显示时间，可更改时间，默认当前时间；

“Sys Time” submenu, we can check and modify time, the default is current time;

“语言设置”子菜单下可设置界面显示的语言，默认中文；

“Language” submenu, we can set the language of device, the default is Chinese;

“通讯设置”子菜单下可设装置的地址、波特率、数据位、停止位、校验方式，默认 001-9600-8-1-无校验；

“Com set” submenu, we can set address, baud rate, data bit, stop bit and parity, the default setting is 001-9600-8-1-NONE;

“电量设置”子菜单下可设置电压单位、接线类型，默认 V-3P3W；

“Elec set” submenu, we can set voltage unit, line mode, the default setting is V-3P3W;

“出厂设置”子菜单下可恢复出厂默认设置。修改方法：进入子菜单，按“Enter”键选择，然后按左右键选择“是”，再按“Enter”键确认，弹出对话框，按“Enter”键恢复出厂设置，按“SET”键取消操作。

“Reset” submenu, we can reset the device to default, the method is: enter the submenu, press “Enter” and select “Yes” by left or right button, then press “Enter” button, prompt information will be show, press “Enter” button to reset, press “SET” button to cancel.

注意：恢复出厂后，除无线温度配对数据外，其他所有参数都将恢复为出厂默认设置，恢复出厂后设备重新上电后生效！

Notice: After reset the device, all of parameters will be reset to defaults except wireless temperature sensors data. It will be valid after the device restart.

(4) 主菜单页面下，选择“节温”菜单并确认，即进入无线测温显示界面。

(4) In main menu, select “Temp” submenu and confirm, then enter the “Temperature” interface.

(5) 主菜单页面下，选择“定值”菜单并确认，即进入定值设置界面，默认密码为“0008”。

(5) In main menu, select “Para” submenu and confirm, then enter the “Values” interface, the default password is “0008”.

“定值”菜单可以设置装置的温度阈值，包括节点投退，高温预警值，超温告警值，相间告警值。例如，节温1投退设置为“投入”，则当传感器测得的温度高于设定的温度时，继电器输出触点闭合。

“Values” submenu, we can set the temperature threshold, including the “Node Enable”, “high temperature” and “over temperature” and “compare” values. For example, if “Node1 Enable” is “ON”, the relay output contact will be closed while the node1 group temperature values exceed the setting values.

(6) 主菜单页面下，选择“开入”菜单并确认，即进入开入显示界面。

(6) In main menu, select “DI” submenu and confirm, then enter the “DI Status” interface.

(7) 主菜单页面下，选择“开出”菜单并确认，即进入开出显示界面。

(7) In main menu, select “DO” submenu and confirm, then enter the “DO Status” interface.

(8) 主菜单页面下，选择“电量”菜单并确认，即进入电量显示界面。

(8) In main menu, select “Elec” submenu and confirm, then enter the “Electricity” interface.

(9) 主菜单页面下，选择“告警”菜单并确认，即进入告警显示界面。

(9) In main menu, select “Alam” submenu and confirm, then enter the “Alarm Messages” interface.

(10) 主菜单页面下，选择“调试”菜单并确认，即进入系统调试界面。

(10) In main menu, select “Debug” submenu and confirm, then enter the “System Debug” interface.

“节温类型”子菜单下可设置传感器类型，传感器类型分为 ATE100、ATE300、ATE400 三种，节温类型即是传感器型号（ATE100 类型可以连接 ATE200），默认为 ATE100。

“Sensor Type” submenu, we can set the type of sensor, there are 3 types: ATE100, ATE200 and ATE300, specially, ATE100 type can connect ATE200 too. The default is ATE100.

“节温设置”，子菜单下可在线绑定温度传感器，绑定方法为：进入节温设置界面后通过左右键先选中要绑定的节点，然后按“Enter”键，光标会选中“0x□FFF”，查看传感器上标签，比如“FF FF FF FF FF FF 07 E3”，ATE400 传感器的标签为“119071023007E3”，通过左右键输入“0x07E3”，再按“Enter”键确认，光标会定位到节点名称上，完成后按“SET”键退出，如果有修改，界面会提示是否保存修改过的设置，再按“Enter”键保存即可。如果传感器为 ATE100/200 且关闭状态请打开传感器开关。在线绑定方式适合修改个别传感器的配对，多个传感器的配对建议使用配套调试软件。（V1.36 及以上版本支持手动输入 ID）。

“Sensor Setting”, we can bind sensor ID online, the method is: enter the submenu and select node by left or right button, then press “Enter”, “0x□FFF” will be selected, check the label on the sensor, like “FF FF FF FF FF FF 07 E3”, the label of ATE400 is like “119071023007e3”, input “0x07E3” by left or right button, then press “Enter” button, the cursor will be back to node selected. Press “SET” and back to last interface, if modified, prompt information will be show on the screen, press “Enter” button for confirm. If sensor type is 2.4GHz, and it is closed, turn on the switch. Binding sensor ID online is suit for a few sensors, use debug software if there are a large number of sensors. (User can input sensor ID manually if the version is V1.36 and above).

“节温校准”，子菜单下可校准已绑定传感器的温度，校准方法为：进入校准界面后通过左右键先选中要校准的节点，然后按“Enter”键，光标会选中温度值，修改为当前实际温度值，再按“Enter”键确认（光标会定位到节点名称上），修改完成后按“SET”键退出，如果有修改，界面会提示是否保存修改过的设置，然后再按“Enter”键保存即可，按“SET”键取消操作。

“Calibrate”, we can calibrate the temperature values of registered sensors, the method is: enter the submenu and select node by left or right button, then press “Enter”, the temperature value will be selected, modify the value to current temperature, then press “Enter” button (node will be selected), after all of temperature values have be modified, press “SET”, if modified, prompt information will be show on the screen, press “Enter” button to confirm, press “Set” button to cancer.

“继电控制”，子菜单下可设置开出模式，模式分为：

“DO Control”, we can set the mode of relay output, the 3 modes are:

ON: 设备上电后，继电器常闭触点为断开，常开触点为闭合，适用于手动控制（After the device power on, the relay output closing contactor is open, opening contact is close, it is suitable for manual）；

OFF: 设备上电后，继电器常闭触点为闭合，常开触点为断开，适用于手动控制（After the device power on, the relay output closing contactor is close, opening contact is open, it is suitable for manual）；

Def.: 由内部逻辑控制继电器的闭合或断开（the status of relay output contactor is depends on inside software logic）。

“电量校准”，子菜单下可校准电参量，校准方法为：进入校准界面后通过左右键先选中

“Yes”，然后按“Enter”键，再按“SET”键退出，如果有修改，界面会提示是否保存修改过的设置，然后再按“Enter”键保存即可，按“SET”键取消操作。

“UI Calib”, we can calibrate the electric quantity, the method is: enter the submenu and select “Yes” by left or right button, then press “Enter”, press “SET”, if modified, prompt information will be show on the screen, press “Enter” button to confirm, press “Set” button to cancer.

(11) 主菜单页面下，选择“信息”菜单并确认，即进入信息显示界面。

(11) In main menu, select “Info” submenu and confirm, then enter the “Information” interface.

2.4 ARTM-Pn 操作流程

2.4 ARTM-Pn Operation Process

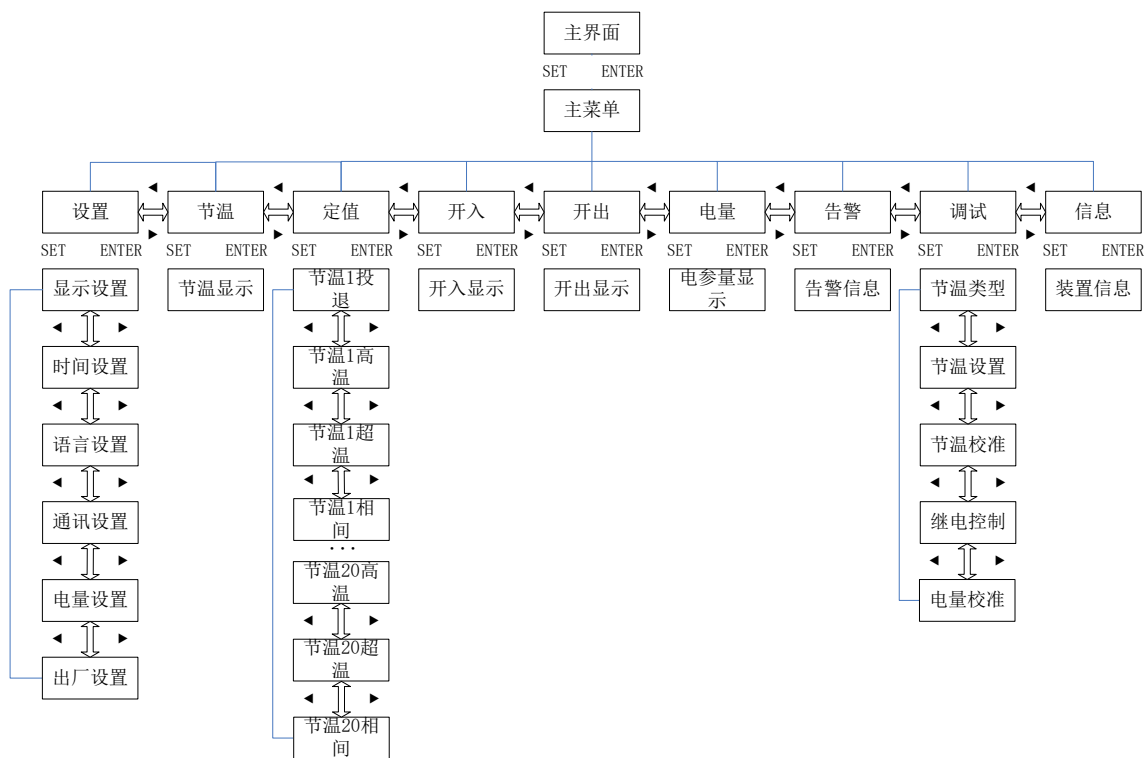

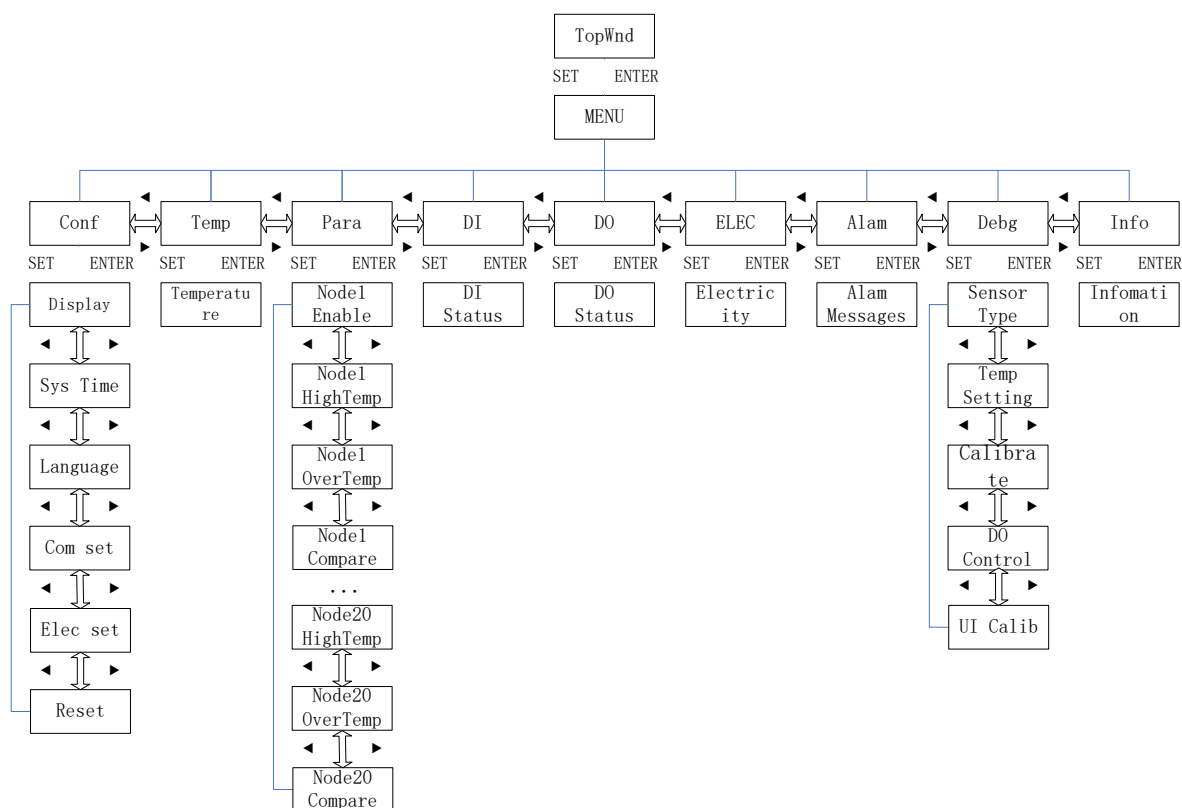

3 通讯指南

3 Communications

在本章主要讲述如何利用软件通过 RS485 通讯口来操控本产品。本章内容的掌握需要您具有 Modbus 协议的知识储备并且通读了本册其他章节所有内容，对本产品功能和应用概念有较全面的了解。本章内容包括：通讯应用格式详解，产品的应用细节及参量地址表。

This chapter focuses on how to use software to control the device through RS485 communication port. The mastery of the content in this chapter requires that you have the knowledge reserve of Modbus protocol and read all the contents of other chapters in this manual, and have a comprehensive understanding of the functions and application concepts of the device. The contents of this chapter include: details of communication format, details of product application and parameter address table of the device.

3.1 通讯格式详解

3.1 Communication Examples

本节所举实例将尽可能的使用如下表所示的格式，数据为十六进制。

The examples in this section will use the format shown in the following table as much as possible, the number is hexadecimal.

3.1.1 读取状态（功能码 02H）

3.1.1 Read State (Function code 02H)

此功能允许用户获得设备采集与记录的状态。主机一次请求的数据个数没有限制，但不能超出定义的地址范围。（V1.35 及以上支持）

This function allows the user to get the states measured and recorded by slave. There is no limit of data length for asking data, but it cannot exceed the range of defined address. (Support V1.35 and above)

例如，主机发送数据帧：

For example, master send data frame:

地址 Addr	功能码 Fun	寄存器地址 Register Addr		寄存器数量 Register Count		CRC16 校验码 CRC16	
		高 Hi	低 Lo	高 Hi	低 Lo	高 Hi	低 Lo
01H	02H	00H	00H	00H	30H	78H	1EH

装置返回响应数据帧：

Slave answer data frame:

地址 Addr	功能码 Fun	字节数 Byte count	数据 1 Data 1		数据 2 Data 2		数据 3 Data 3		CRC16 校验码 CRC16	
			高 Hi	低 Lo	高 Hi	低 Lo	高 Hi	低 Lo	高 Hi	低 Lo
01H	02H	06H	00H	00H	00H	00H	00H	FCH	E0H	F8H

3.1.2 读取数据（功能码 03H/04H）

3.1.2 Read Data (Function code 03H/04H)

此功能允许用户获得设备采集与记录的数据及系统参数。主机一次请求的数据个数没有限制，但不能超出定义的地址范围。

This function allows the user to get the data measured and system parameters recorded by slave. There is no limit of data length for asking data, but it cannot exceed the range of defined address.

例如，主机发送数据帧：

For example, master send data frame:

地址 Addr	功能码 Fun	寄存器地址 Register Addr		寄存器数量 Register Count		CRC16 校验码 CRC16	
		高 Hi	低 Lo	高 Hi	低 Lo	高 Hi	低 Lo
01H	03H	00H	30H	00H	03H	05H	C4H

装置返回响应数据帧：

Slave answer data frame:

地址 Addr	功能码 Fun	字节数 Byte count	数据 1 Data 1		数据 2 Data 2		数据 3 Data 3		CRC16 校验码 CRC16	
			高 Hi	低 Lo	高 Hi	低 Lo	高 Hi	低 Lo	高 Hi	低 Lo

01H	03H	06H	00H	00H	00H	00H	00H	00H	21H	75H
-----	-----	-----	-----	-----	-----	-----	-----	-----	-----	-----

3.1.3 预置单个寄存器（功能码 06H）

3.1.3 Preset Single Register (Function code 06H)

此功能码允许用户改变单个寄存器的内容，可通过此功能码将工作参数写入装置。

User can write active parameter into the single register with this function code.

例如，主机发送数据帧：

For example, master send data frame:

地址 Addr	功能码 Fun	寄存器地址 Register Addr		预置值 Value		CRC16 校验码 CRC16	
		高 Hi	低 Lo	高 Hi	低 Lo	高 Hi	低 Lo
01H	06H	00H	03H	03H	E8H	74H	79H

装置返回响应数据帧：

Slave answer data frame:

地址 Addr	功能码 Fun	寄存器地址 Register Addr		预置值 Value		CRC16 校验码 CRC16	
		高 Hi	低 Lo	高 Hi	低 Lo	高 Hi	低 Lo
01H	06H	00H	03H	03H	E8H	74H	79H

3.1.4 预置多个寄存器（功能码 10H）

3.1.4 Preset Multi Registers (Function code 10H)

此功能码允许用户改变多个寄存器的内容，可通过此功能码将工作参数写入装置。

User can write active parameter into the multi registers with this function code.

例如，主机发送数据帧：

For example, master send data frame:

地址 Addr	功能码 Fun	寄存器地址 Register Addr		寄存器数量 Register Count		字节数 Byte Count	预置值 1 Value 1		预置值 2 Value 2		CRC16 校验码 CRC16	
		高 Hi	低 Lo	高 Hi	低 Lo		高 Hi	低 Lo	高 Hi	低 Lo	高 Hi	低 Lo
01H	10H	00H	03H	00H	02H	04H	00H	28H	00H	64H	59H	32H

装置返回响应数据帧：

Slave answer data frame:

地址 Addr	功能码 Fun	寄存器地址 Register Addr		寄存器数量 Register Count		CRC16 校验码 CRC16	
		高字节 Hi	低字节 Lo	高字节 Hi	低字节 Lo	高字节 Hi	低字节 Lo
01H	10H	00H	03H	00H	02H	B1H	C8H

3.2 参量地址表

3.2 Parameter Address Table

地址 ^[1] Address	参数 Parameter	属性 ^[2] Attribute	数值范围 Range	数据类型 Data type
10001~ 10002	继电器输出 Relay Output	R	DO1, DO2	bit*2
10003~ 10006	开关量输入 Digital Input	R	DI1, DI2, DI3, DI4	bit*4
10007~ 10066	节温高温报警状态 High temperature	R	0-正常, 1-告警, 节温 1A~节温 20C 高温 0-normal, 1-alarm, Node1A~Node 20C high temperature	bit*60
10067~ 10126	节温超温报警状态 Over temperature	R	0-正常, 1-告警, 节温 1A~节温 20C 超温 0-normal, 1-alarm, Node1A~Node 20C over temperature	bit*60
10127~ 10146	节温控制字 Node Enable	R	0-退出, 1-投入, 节温 1~节温 20 控制字 0-OFF, 1-ON, Node 1~Node 20 enable for relay output alarm	bit*20
10147~ 10152	预留 Reserved	R	预留补充字节 Reserved for filling full byte	bit*6
30001	通讯地址 Address	R/W	001-247	Word
30002	通讯波特率 Baud rate	R/W	2400、4800、9600、19200	Word
30003	背光时间 Backlight time	R/W	000-999s, 000 为常亮 000-999s, 000 is for lighting on all the time	Word
30004	循环时间 cycling time	R/W	000-999s, 000 为常态 000-999s, 000 is for normal display	Word
30005	继电器输出 Relay Output	R/W	bit0~bit1: 高温预警, 超温告警 bit0~bit1: high temperature alarm, over temperature alarm	word
30006	开关量输入 Digital Input	R	bit0-bit3: DI1-DI4。	Word
30007	节温高温报警状态 1 High temperature Alarm state 1	R	0-正常, 1-告警。bit0~bit14: 节温 1A~节温 5C 高温 0-normal, 1-alarm. bit0~bit14: Node1A~Node 5C high temperature	Word
30008	节温高温报警状态 2 High temperature Alarm state 2	R	0-正常, 1-告警。bit0~bit14 分别对应: 节温 6A~节温 10C 高温 0-normal, 1-alarm. bit0~bit14: Node6A~Node	Word

			10C high temperature	
30009	节温高温报警状态 3 High temperature Alarm state 3	R	0-正常, 1-告警。bit0~bit14 分别对应: 节温 11A~节温 15C 高温 0-normal, 1-alarm. bit0~bit14: Node11A~Node 15C high temperature	Word
30010	节温高温报警状态 4 High temperature Alarm state 4	R	0-正常, 1-告警。bit0~bit14 分别对应: 节温 16A~节温 20C 高温 0-normal, 1-alarm. bit0~bit14: Node16A~Node 20C high temperature	Word
30011	节温超温报警状态 1 Over temperature Alarm state 1	R	0-正常, 1-告警。bit0~bit14: 节温 1A~节温 5C 超温。 0-normal, 1-alarm. bit0~bit14: Node1A~Node 5C over temperature	Word
30012	节温超温报警状态 2 Over temperature Alarm state 2	R	0-正常, 1-告警。bit0~bit14 分别对应: 节温 6A~节温 10C 超温 0-normal, 1-alarm. bit0~bit14: Node6A~Node 10C over temperature	Word
30013	节温超温报警状态 3 Over temperature Alarm state 3	R	0-正常, 1-告警。bit0~bit14 分别对应: 节温 11A~节温 15C 超温 0-normal, 1-alarm. bit0~bit14: Node11A~Node 15C over temperature	Word
30014	节温高温报警状态 4 Over temperature Alarm state 4	R	0-正常, 1-告警。bit0~bit14 分别对应: 节温 16A~节温 20C 超温 0-normal, 1-alarm.bit0~bit14: Node16A~Node 20C over temperature	Word
30015	节温控制字 1 Node Enable 1	R/W	报警继电器控制字: 0-退出, 1-投入; bit0~bit9: 节温 1~节温 10。 Node enable for relay output alarm: 0-OFF, 1-ON; bit0~bit9: Node 1~Node 10.	Word
30016	节温控制字 2 Node Enable 2	R/W	报警继电器控制字: 0-退出, 1-投入; bit0~bit9: 节温 11~节温 20。 Node enable for relay output alarm: 0-OFF, 1-ON; bit0~bit5: Node 11~Node 20.	Word
30017 ~30056	无线温度传感器告警 温度定值 Wireless temperature sensor alarm temperature value	R/W	告警温度定值: 节温 1 高温, 节温 1 超温~ 节温 20 高温, 节温 20 超温, 默认高温 60.0, 超温 80.0; 范围: 0-125.0 ($\times 10$) ^[3] Alarm temperature value: Node1 HighTemp, Node1 OverTemp ~ Node20 OverTemp, Node20 OverTemp, default: HighTemp 60.0, OverTemp 80.0; Range: 0~125.0 ($\times 10$)	Word*40

30057~ 30116	无线温度传感器 温度值 Wireless temperature sensor value	R	节点温度值：节温 1A~节温 20C；范围： 0-125.0 (×10) Node temperature value: Node1A~Node20C; range: 0~125.0 (×10)	Word*60
30117 ^[4]	环境温度 Ambient temperature	R	环境温度：ATC300 环境温度值；范围： -50~85.0 (×10) Ambient temperature: ATC300 ambient temperature value; Range: -50~85.0 (×10)	Word
30118~ 30124 ^[5]	时间参数 Time parameter	R/W	时间：年月日时分秒毫秒；范围：年 2000~2050，其他常规 Time: year, month, day, hour, minutes, second, millisecond; Range: year 2000~2050, other parameters are normal	Word*7
30125	节温相间温度报警状 态 1 Compare temperature Alarm state 1	R	0-正常，1-告警。bit0~bit14：节温 1A~节温 5C 相间温度 0-normal, 1-alarm. bit0~bit14: Node1A~Node 5C compare temperature	Word
30126	节温相间温度报警状 态 2 Compare temperature Alarm state 2	R	0-正常，1-告警。bit0~bit14 分别对应： 节温 6A~节温 10C 相间温度 0-normal, 1-alarm. bit0~bit14: Node6A~Node 10C compare temperature	Word
30127	节温相间温度报警状 态 3 Compare temperature Alarm state 3	R	0-正常，1-告警。bit0~bit14 分别对应： 节温 11A~节温 15C 相间温度 0-normal, 1-alarm. bit0~bit14: Node11A~Node 15C compare temperature	Word
30128	节温高温报警状态 4 High temperature Alarm state 4	R	0-正常，1-告警。bit0~bit14 分别对应： 节温 16A~节温 20C 高温 0-normal, 1-alarm. bit0~bit14: Node16A~Node 20C compare temperature	Word
30129~ 30148	无线温度传感器告警 相间温度定值 Wireless temperature sensor alarm temperature value	R/W	告警温度定值：节温 1 相间温度~节温 20 相间温度，默认相间温度 10.0；范围：0-125.0 (×10) ^[3] Alarm temperature value: Node1 CompareTemp~ Node20 CompareTemp, default: HighTemp 10.0,	Word*20
30149~ 30208	无线温度传感器 ID Wireless temperature sensor ID	R	节温 1A-节温 20C 无线温度传感器 ID，用十 六进制数表示 Node1A~Node20C wireless temperature sensor ID, in hexadecimal number	Word*60
30209- 30210	相电压 UA Phase voltage	R	一次侧：0.0~99999999.99KV(V) ^[8] Primary Side:0.0~99999999.99KV (V) ^[8]	Float
30211- 30212	相电压 UB Phase voltage	R	一次侧：0.0~99999999.99KV(V) ^[8] Primary Side:0.0~99999999.99KV(V) ^[8]	Float

30213-30214	相电压 UC Phase voltage	R	一次侧: 0.0~99999999.99KV(V) ^[8] Primary Side:0.0~99999999.99KV (V) ^[8]	Float
30215-30216	线电压 UAB Line voltage UAB	R	一次侧: 0.0~99999999.99KV(V) ^[8] Primary Side:0.0~99999999.99KV(V) ^[8]	Float
30217-30218	线电压 UBC Line voltage UAB	R	一次侧: 0.0~99999999.99KV(V) ^[8] Primary Side:0.0~99999999.99KV (V) ^[8]	Float
30219-30220	线电压 UCA Line voltage UCA	R	一次侧: 0.0~99999999.99KV(V) ^[8] Primary Side:0.0~99999999.99 KV(V) ^[8]	Float
30221-30222	Ia	R	一次侧: 0.0~99999999.99 Primary Side:0.0~99999999.99	Float
30223-30224	Ib	R	一次侧: 0.0~99999999.99 Primary Side:0.0~99999999.99	Float
30225-30226	Ic	R	一次侧: 0.0~99999999.99 Primary Side:0.0~99999999.99	Float
30227-30228	PA	R	0.0~99999999.99KW(W) ^[8]	Float
30229-30230	PB	R	0.0~99999999.99KW(W) ^[8]	Float
30231-30232	PC	R	0.0~99999999.99KW(W) ^[8]	Float
30233-30234	P 总 P total	R	0.0~99999999.99KW(W) ^[8]	Float
30235-30236	QA	R	0.0~99999999.99Kvar(var) ^[8]	Float
30237-30238	QB	R	0.0~99999999.99Kvar(var) ^[8]	Float
30239-30240	QC	R	0.0~99999999.99Kvar(var) ^[8]	Float
30241-30242	Q 总 Q total	R	0.0~99999999.99Kvar(var) ^[8]	Float
30243-30244	PFA	R	0.0~1.0	Float
30245-30246	PFB	R	0.0~1.0	Float
30247-30248	PFC	R	0.0~1.0	Float
30249-30250	PF 总 PF total	R	0.0~1.0	Float
30251-30252	SA	R	0.0~99999999.99KVA(VA) ^[8]	Float
30253-30254	SB	R	0.0~99999999.99KVA(VA) ^[8]	Float
30255-30256	SC	R	0.0~99999999.99KVA(VA) ^[8]	Float

30257-30258	S 总 S total	R	0.0~99999999.99KVA(VA) ^[8]	Float
30259-30260	频率 Freq Frequency Freq	R	45.0~65.0	Float
30261-30262	电能(高 16 位) Electrical energy(Hi 16)	R	0.0~99999999.99KWh	Float
30263	电量单位设置 Electirc uint set	R/W	电量单位设置: 0-KV,1-V Electirc uint setting: 0-KV,1-V	Word
30264	接线类型设置 Line mode set	R/W	接线类型设置: 0-3P3W,1-3P4W Electirc uint setting: 0-3P3W,1-3P4W	Word

注: [1] 地址: 10001—功能码为 02, 地址从 0 开始; 30001—功能码为 03/04, 地址从 0 开始 (Address: 10001-function code is 02, address is from 0; 30001-function code is 03/04, address is from 0)。

[2] 属性: R—只读; R/W—可读可写 (Attribute: R-Read; R/W-Read/Write)。

[3] ×10—读取时实际值乘以相应的倍数上传, 写入时应乘以相应的倍数写入 (Read with the ratio and write with the ratio in the table)。

[4] 30117—0074H 地址, ATC300 环境温度寄存器, V1.36 及以上支持 (30117—0074H Address, ambient temperature from ATC300 register, support V1.36 or above)。

[5] 30118~30123—75H~7AH, 时间存储寄存器, 对时必须 7 个寄存器写入, 且不能超过范围 (30118~30123—75H~7AH, Time register, if master send time data into device, it must be 7 registers and forbid to write data out of range in the table)。

[6] 30125~30148—7CH~93H, 相见温度告警状态寄存器和相见温度定值寄存器, V1.60 及以上支持 (30125~30148—7CH~93H Address, the meet temperature alarm status register and the meet temperature setting register, support V1.60 or above)。

[7] 30209~302,264—D0H~107H, 电量参数寄存器, V1.60 及以上支持 (30209~30264—D0H~107H Address, electric quantity parameter register, support V1.60 or above)。

[8] 电量单位依据 30264 电量单位设置 (Electric quantity unit is set according to 30237 electric quantity unit)。

注意: 参量地址表与软件版本有关, 请注意版本号, 此表适用于 V1.38 及以上版本, 如有任何疑问, 请联系我们。(Parameter address table related to software version, please pay attention to the version, this table is suit for V1.38 and above, if you have any questions, please contact us.)

4 常见故障的诊断分析与排除方法

4 The Analysis and Solvent of Some Faults

4.1 辅助电源故障

4.1 Power Source Fault

装置接通辅助电源后屏幕不亮？

The LCD does not work after the device power on?

可能原因：外接端子线序错误。

Reason: Wiring connector connects to power source wrong.

处理方法：拔出“无线测温”接口处的外接模块，检查电源端口，重新上电装置判断。

Solvent: Take off the connector of “Wireless Temp”, check up the power source connector, and power on it again.

4.2 告警继电器动作故障

4.2 Relay Output Fault

无线测温节点温度定值越限而继电器不动作？

When measured wireless temperature values exceed the setting values, the relay output does not work?

可能原因：相应的控制字未投入。

Reason: “Node Enable” is not “ON”.

处理方法：“主菜单”一>“定值”菜单将相应的控制字设置为投入。

Solvent: “MENU” -> “Para”, Set “Node Enable” to “ON”.

4.3 通信故障

4.3 Communication Fault

上位机或后台软件与装置通信错误？

PC /host computer can't communicate with the device?

可能原因：装置地址或串口参数设置错误。

Reason: The address or other port parameter of communication is wrong.

处理方法：“主菜单”一>“通信”设置正确的装置地址或串口参数。

Solvent: “MENU”->“Comm”, Set valid address or other port parameter.

4.4 节点温度值显示故障

4.4 Wireless Temperature Fault

“节温”菜单无温度值显示或无某一路温度值显示？

On the “Temp” interface, the device shows “No Nodes or Nodes Fault”?

可能原因：传感器电池开关未打开或未启动，传感器不配对。

Reason: Active wireless temperature sensor battery is closed or passive wireless temperature sensor does not work, or the sensor is not matched to the device.

处理方法：（1）查看无线温度传感器的电池开关是否拨到“ON”端？（电池开关从 OFF 端拨到 ON 端后，无线温度传感器上的绿灯亮灭闪烁 2 次表示开关接通正常，否则等待 5s 后重拨）；查看无源测温传感器相应回路是否正常运行，且电流 8A 以上。

Solvent: (1) Check up the active wireless temperature whether its battery switch is “ON”? (When the battery switch turn to ON from OFF, the green light will lighting twice, it is worked, otherwise, wait for 5s and turn on it again); check up the circuit whether it worked with the current above 8A.

（2）查看装置上的条码与无线温度传感器上的条码是否一致，不一致时找到对应的无线温度传感器更换或重新配对无线温度传感器（详见本说明书 2.3 章节下的“节温设置”）。

(2) Check up the bar code on wireless temperature sensor and device, if they are not same, find out the sensors with same bar code or bind the sensors online (the detailed method is at “Sensor Setting” in chapter 2.3).